

Label Printer Applicator System

Integrated thermal transfer printer, applicator, tray conveyor with stand. Print 300 dpi one color oven-safe labels precisely applied to top film lid of trays. Print information such as menu, nutritional content, packaged on, consume by dates and even bar codes.

Features

- One color printer with 4" wide print head
- Clarisuite™ software license
- Software compatible with label design software which supports Zebra or Sato print engines
- Uses industry standard labels
- Label content database capacity of 400 MB
- USB port for label upload and backup/restore
- Supports 20 different languages
- Touch screen operator panel with video tutorials for set up, consumables loading, troubleshooting and print-head replacement
- Adjustable stand (height) and conveyor (speed and tray guide rails), with lockable casters
- System set up for left or right side mount on conveyor, dependent on space, location, preference within production space

Benefits

- Precise placement of labels for consistent product presentation
- Enhance meal presentation with product labeling for improved consumer experience
- Satisfy state requirements for product identification with easy to read labels
- Minimal setup steps—conveyor guides and printer/applicator head distance to tray—make integration into meal production simple and quick
- Easily roll in and out for production line flexibility
- Supported by a nationwide service organization
- One-year warranty from date of installation



Label Printer Applicator System

Specifications

System Dimensions

- 49.03" W x 49.74" L

Electrics

- 115 VAC

Label Size Options

(one roll included with system purchase)

- 3" x 4" - 8,800/roll
- 3" x 5" - 7,000/roll
- 4" x 4" - 8,800/roll
- 4" x 6" - 5,800/roll

Ribbon Size

(one roll included with system purchase)

- 4" wide

Shipping Weight

- Labeler - 165 lbs
- Integrated stand/conveyor - 575 lbs

Integrated stand/conveyor shipping pallet dimensions - 66" L x 48" W x 68" H

Labeler/printer/applicator shipping pallet dimensions - 30" L X 35" W X 40" H

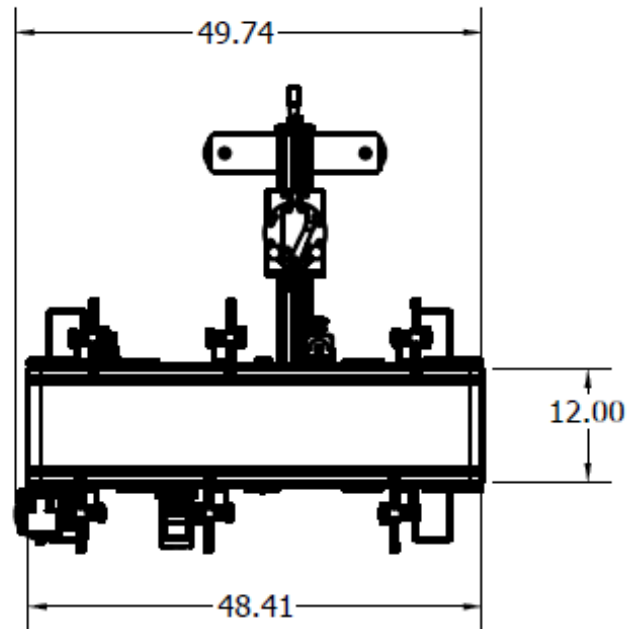

Top view

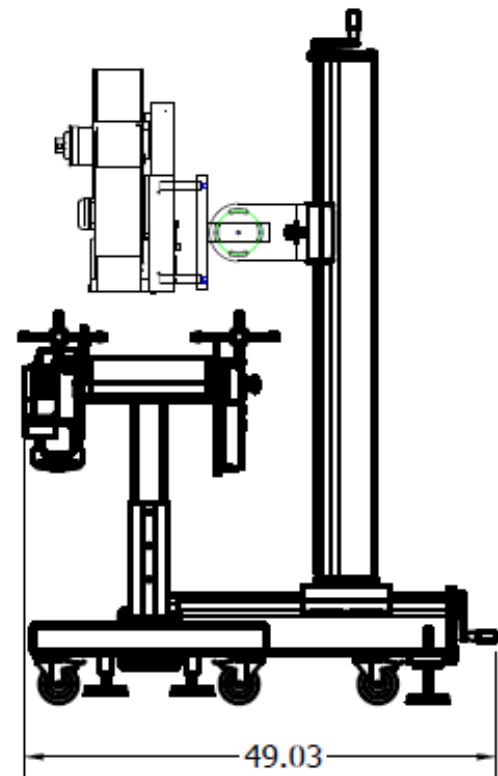

Side view

Made in the USA

Above specifications subject to change without notice.
The information contained herein is correct as of the date hereof.
080524

Label Printer Applicator System

System Dimensions with Oliver Model MX Model 1808



MX Model 1808 with Label Printer Applicator System

Overall length: 10', 9.75"

Width of stand: 4', 1.5"



MX Model 1808 with Label Printer Applicator System and Accumulator Table

Overall length: 13', 10"

Width front of accumulator to back of stand: 4', 5.75"

Label Printer Applicator System

System Dimensions with Oliver Models MX-2 Model 1908

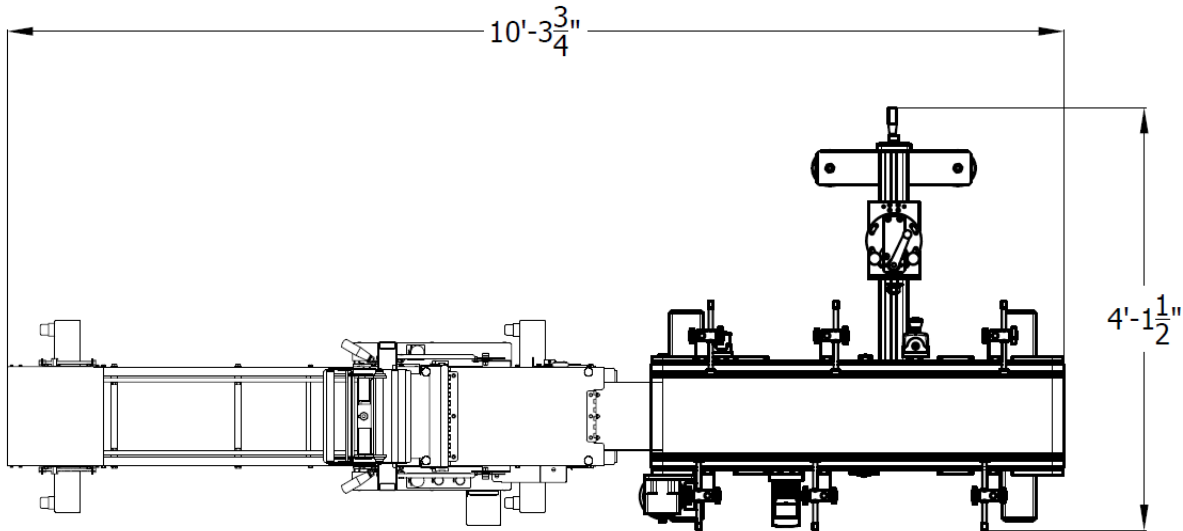

MX-2 Model 1908 with Label Printer Applicator System

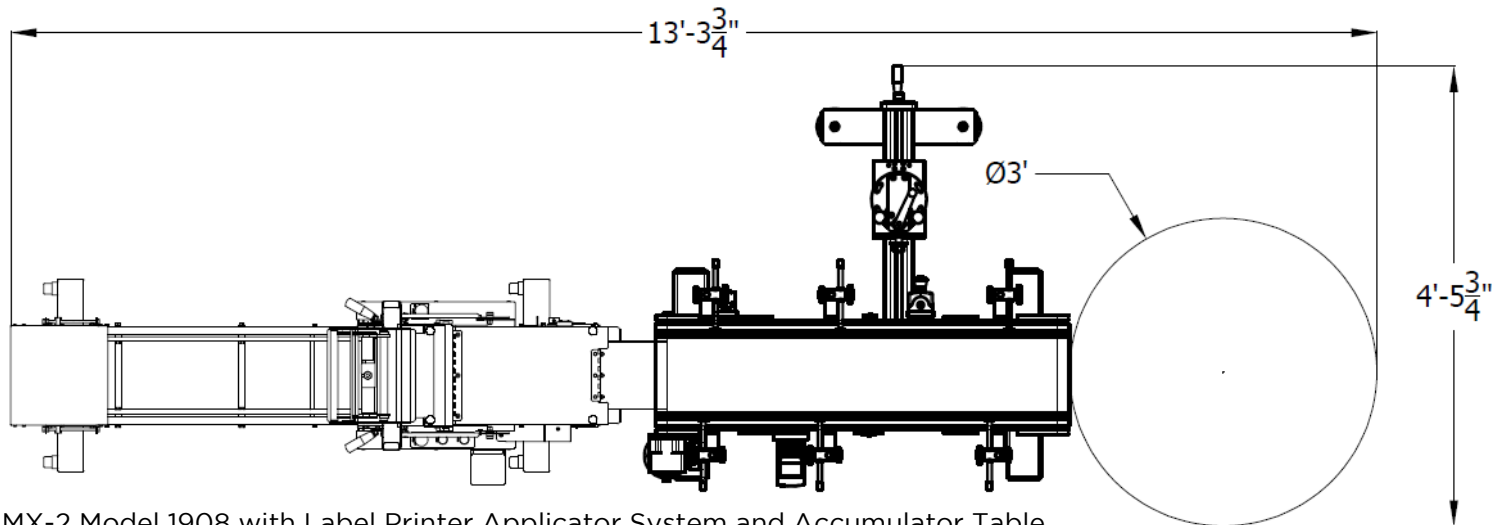

MX-2 Model 1908 with Label Printer Applicator System and Accumulator Table