



Walker, Michigan, U.S.A. 49534-7564

**USER'S OPERATING AND INSTRUCTION MANUAL**

**MODEL 705-N**

DUAL BLADE BUN SLICER



---

---

MODEL 705-N DUAL BLADE BUN SLICER

---

---

**INDEX**

SLICER SPECIFICATIONS.....	0705S20012
Description .....	0705S20012-1/2
Specifications .....	0705S20012-1/2
Product Capacities .....	0705S20012-2/2
SAFETY INSTRUCTIONS.....	0705S20013
DEFINITIONS .....	GEN 931118
ADJUSTMENTS.....	0705S20014
Inside Side Guides .....	0705S20014-1/2
Table Height Adjustment .....	0705S20014-1/2
Overhead Hold Down Adjustment .....	0705S20014-2/2
Slow-Down Door Adjustment .....	0705S20014-2/2
OPERATING INSTRUCTIONS.....	0705S20015
MAINTENANCE/CLEANING/LUBRICATION.....	0705S20016
Maintenance .....	0705S20016-1/2
Cleaning .....	0705S20016-1/2
Lubrication.....	0705S20016-2/2
CHANGING THE BLADES .....	0705S20017
TROUBLE SHOOTING .....	0705S20018
PARTS LIST.....	0705S20019
ASSEMBLY DRAWING MODEL 705-N SLICERS .....	0705S20020
WIRING DIAGRAMS .....	0705S20021
WARRANTY.....	GEN 040225
WARRANTY PROCEDURE.....	GEN 040226
RETURNED PARTS POLICY.....	GEN 040227

REV. 2/27/04



---

## MODEL 705-N DUAL BLADE BUN SLICER

---

### SPECIFICATIONS

#### DESCRIPTION

These bun slicers have welded steel frames and stainless steel chutes. They are compact, durable slicers for counter top use in slicing a variety of large buns with speed and economy.

#### SPECIFICATIONS

- Machine dimensions:

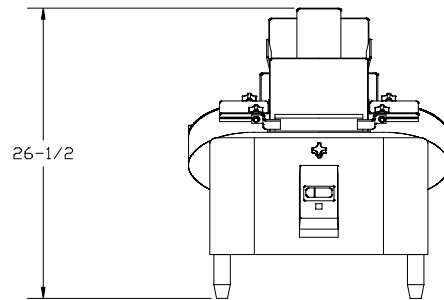
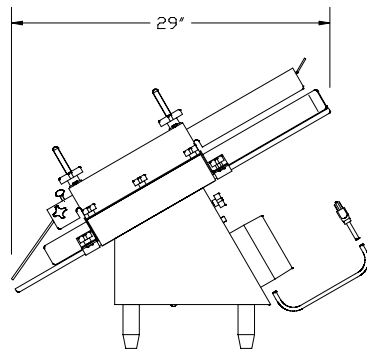
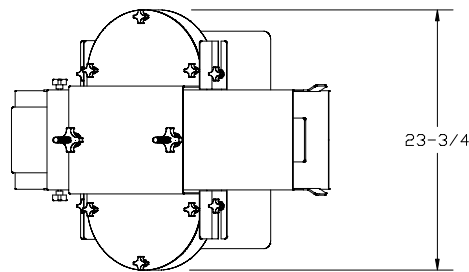

- Weight: Approximately 150 pounds.
- Standard Color: Gloss white enamel.
- Standard Electrical Service:  
2/3 HP, 1725 RPM, 1-60-115 Volts AC, 12 Amps.
- Optional Electrical Services:  
2/3 HP, 1725 RPM, 1-60-230 Volts AC, 6 Amps.  
2/3 HP, 1425 RPM, 1-50-220 Volts AC, 7 Amps.



Oliver Packaging & Equipment Company  
3236 WISON DR NW WALKER MI. 49534

(800) 253-3893  
www.oliverquality.com

---

## MODEL 705-N DUAL BLADE BUN SLICER

---

### **SPECIFICATIONS (Continued)**

#### PRODUCT CAPACITIES

- Maximum Product Size:  
8-3/4 inches Wide and 4-1/8 inches High
- Blade Height (adjustable to cut bottom slice):  
5/8 inch to 1-1/2 inches



---

## MODEL 705-N DUAL BLADE BUN SLICER

---

### SAFETY INSTRUCTIONS

Every effort has been made by Oliver Products Company to provide you with a safe machine. It is essential, however, that machine operators and maintenance personnel observe the following safety precautions.

1. Before attempting to operate your slicer read this manual. Never allow an untrained person to operate this machine.
2. Make sure that the machine is only connected to a properly grounded electrical supply source of sufficient capacity for the load the slicer will put on it. Always unplug the machine when it is not in use.
3. Always make sure the machine has been disconnected from the power supply before cleaning or servicing.
4. Never stick your hand or any other objects into either end of the chute. Keep your hands away from the moving parts of the machine.
5. Never attempt to adjust or service this machine until your are **SURE** the blades have stopped.
6. Always make sure the blades are not rubbing or hitting any metal components before re-starting the machine.
7. All guards must be in place before starting the machine.
8. Handle knife blades with care. Do not touch the moving blades.
9. Use only proper replacement parts.
10. In addition to these general safety instructions, also follow the more specific safety instructions given for the different areas of the machine in the operating instructions.



## GENERAL

### DEFINITIONS

The use of the words WARNING, CAUTION, and NOTE in this manual should be guided by the following.

#### **WARNING**

AN OPERATING PROCEDURE, TECHNIQUE, ETC., WHICH MAY RESULT IN PERSONAL INJURY IF NOT CAREFULLY FOLLOWED.

#### **CAUTION**

AN OPERATING PROCEDURE, TECHNIQUE, ETC., WHICH MAY RESULT IN DAMAGE TO EQUIPMENT IF NOT CAREFULLY FOLLOWED.

#### **NOTE**

AN OPERATING PROCEDURE, TECHNIQUE, ETC., WHICH IS CONSIDERED ESSENTIAL TO EMPHASIZE.



---

---

MODEL 705-N DUAL BLADE BUN SLICER

---

---

**ADJUSTMENTS**

**WARNING**

NEVER ATTEMPT TO ADJUST OR SERVICE THIS MACHINE UNTIL YOU ARE SURE THE BLADES ARE STOPPED.

**INSIDE SIDE GUIDES**

Normally when the machine is used to slice round product these guides can be set to the maximum opening size and do not need to be readjusted to fit each different product.

When cutting oblong product these guides should be set to a loose fit, (1/4 to 1/2 inch larger), to the product to be sliced. Their function is to prevent product from turning sideways and jamming in the machine.

The guides can be adjusted by loosening the two knobs which secure each to the table, and by sliding the guide in or out to the desired position. Re-tighten the knobs to secure the guide in that location.

Optional non-adjustable guides, (fixed), are available.

**CAUTION**

MAKE SURE THAT THE BLADES ARE NOT HITTING ANY OF THE METAL COMPONENTS BEFORE RE-STARTING THE MACHINE.

**TABLE HEIGHT ADJUSTMENT (Bottom Slice Thickness)**

The table can be adjusted so that the height of the blades above the table is between 5/8" and 1-1/2".

To change the height of the blades relative to the table loosen the knob on the front of the machine's base below the table. Once loosened the thumb wheel can be rotated to either raise or lower the table. Raising the table will decrease the bottom slice thickness while lowering the table will increase its thickness. Once the desired slice thickness is achieved re-tighten the knob on the front of the base to secure the table in the new position.

**CAUTION**

MAKE SURE THAT THE BLADES ARE NOT HITTING ANY OF THE OTHER COMPONENTS BEFORE RE-STARTING THE MACHINE.



---

## MODEL 705-N DUAL BLADE BUN SLICER

---

### OVERHEAD HOLD DOWN ADJUSTMENT

On some buns, especially buns with sunken or rounded tops and bottoms, it may be beneficial to use the Overhead Hold Down. Buns with a flat side normally will not require the use of the hold down, especially if the flat side can be placed against the top of the table.

Turning the large knobs on the top to the machine clockwise will raise the hold down while turning the knob in the counter clockwise direction will lower the hold down.

Normally the hold down should be adjusted so that there is slight compression of the product, (1/8 to 1/4 of an inch). This will make it necessary to load a second and possibly a third bun on the chute to advance the first into slicing position.

### **WARNING**

NEVER STICK YOUR HAND OR ANY OTHER OBJECT INTO EITHER END OF THE CHUTE. ALWAYS KEEP YOUR HANDS AWAY FROM THE MOVING PARTS OF THE MACHINE.

### SLOW-DOWN DOOR ADJUSTMENT

On the discharge end of the chute you will find a adjustable door used to slow the product as it exits the blades. Generally heavier products require a lower door setting while lighter products require less restriction. The door is raised by turning the thumb screw in a clockwise direction. Turning the screw in the opposite direction will lower the door.

Normally if a bun should stop beneath the door the next bun should dislodge it, if it does not then the door should be adjusted to provide less restriction.

### **WARNING**

NEVER STICK YOUR HAND OR ANY OTHER OBJECT INTO EITHER END OF THE CHUTE. ALWAYS KEEP YOUR HANDS AWAY FROM THE MOVING PARTS OF THE MACHINE.





---

## MODEL 705-N DUAL BLADE BUN SLICER

---

### OPERATING INSTRUCTIONS

After making any required adjustments, (see adjustment section), you are ready to begin slicing your product.

Start the motors by pushing the "ON" button of the switch, then place the product on the chute as close to the middle as possible and allow it to slide into the blades, (do not throw the product into the machine). If the buns resist sliding freely into the blade, or the overhead hold down is being used, simply use one or more additional buns to advance the first into slicing position.

#### **WARNING**

NEVER STICK YOUR HAND OR ANY OTHER OBJECT INTO EITHER END OF THE CHUTE. KEEP YOUR HANDS AWAY FROM THE MOVING PARTS OF THE MACHINE.

#### **CAUTION**

NEVER PLACE A PRODUCT IN THE MACHINE BEFORE STARTING THE MOTOR. THIS MAY PREVENT THE BLADES FROM ROTATING AND CAUSE MOTOR DAMAGE.

Should the sliced bun stop under the discharge door, allow the next bun through the blades to dislodge it. If this does not happen, re-adjust the slow down door or inside guides, see adjustment section of this manual.



## MODEL 705-N DUAL BLADE BUN SLICER

### MAINTENANCE/CLEANING/LUBRICATION

#### WARNING

NEVER ATTEMPT TO CLEAN OR SERVICE THIS MACHINE UNTIL IT HAS BEEN DISCONNECTED FROM THE POWER SUPPLY AND YOU ARE SURE THE BLADES HAVE STOPPED. ALSO REMEMBER TO USE CARE WHENEVER YOU ARE WORKING NEAR THE BLADES.

#### MAINTENANCE

Other than normal cleaning and occasional blade replacement little other regular maintenance is required.

#### CLEANING

Use a mild detergent solution or spray cleaner on all exterior and interior surfaces, (such as the chute, guides, and blades), as necessary. Periodically remove the OVERHEAD HOLDDOWN AND CHUTE GUARD ASSEMBLY, then brush, or vacuum, all foreign material from below the table and from the blade compartments.

- Remove the OVERHEAD HOLDDOWN AND CHUTE GUARD ASSEMBLY by removing the six knobs which hold it in place. Lift it clear of the machine and set it aside.

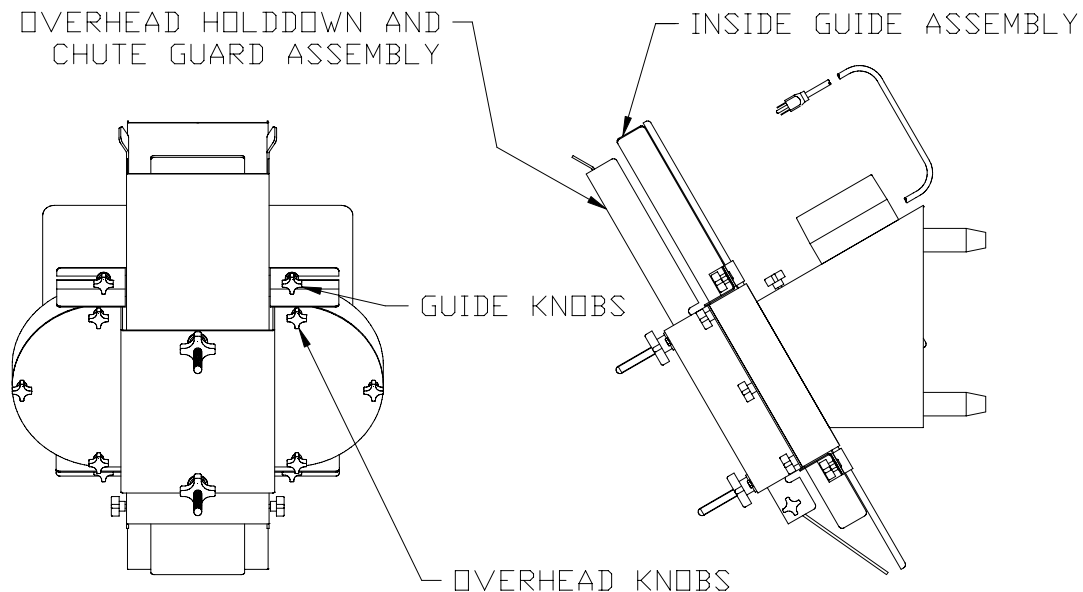

#### WARNING

ALWAYS USE CARE WHEN HANDLING AND CLEANING THE BLADES.



Oliver Packaging & Equipment Company  
3236 WISON DR NW WALKER MI. 49534

(800) 253-3893  
www.oliverquality.com

---

## MODEL 705-N DUAL BLADE BUN SLICER

---

### CLEANING (continued)

The BLADES should be cleaned at least daily and may be cleaned in place, the maintenance person should wear cut resistant gloves to prevent injury. More frequent cleaning of the BLADES is required when cutting fruity or sticky breads.

<b>CAUTION</b>
----------------

ATTEMPTING TO SLICE PRODUCT WITH DIRTY BLADES MAY  
CAUSE MOTOR OVERLOADS -- CLEAN THE BLADES FREQUENTLY.

The BLADES may also be removed for cleaning, which becomes necessary when product is allowed to build up on the BLADE and dry. This may be a problem especially when cutting fruity or sticky breads. See "Changing the Blades" latter in this manual for instruction on how to remove the BLADES.

### LUBRICATION

No lubrication is required. The motor is equipped with pre-lubricated sealed bearings which require NO lubrication, **DO NOT** attempt to oil or grease the motor.



---

## MODEL 705-N DUAL BLADE BUN SLICER

---

### CHANGING THE BLADES

#### **WARNING**

NEVER ATTEMPT TO CLEAN OR SERVICE THIS MACHINE UNTIL IT HAS BEEN DISCONNECTED FROM THE POWER SUPPLY AND YOU ARE SURE THE BLADES HAVE STOPPED. ALSO REMEMBER TO USE CARE WHENEVER YOU ARE WORKING NEAR THE BLADES.

#### CHANGING THE BLADES

- Remove the OVERHEAD HOLDDOWN AND CHUTE GUARD ASSEMBLY by removing the six knobs which hold it in place. Lift it clear of the machine and set it aside. See "Maintenance/Cleaning/Lubrication" in this manual for instruction on how to remove the OVERHEAD HOLDDOWN AND CHUTE GUARD ASSEMBLY.
- Using a 7/16 inch hex wrench remove the three screws securing each BLADE to the hub and lift the BLADE from the machine.

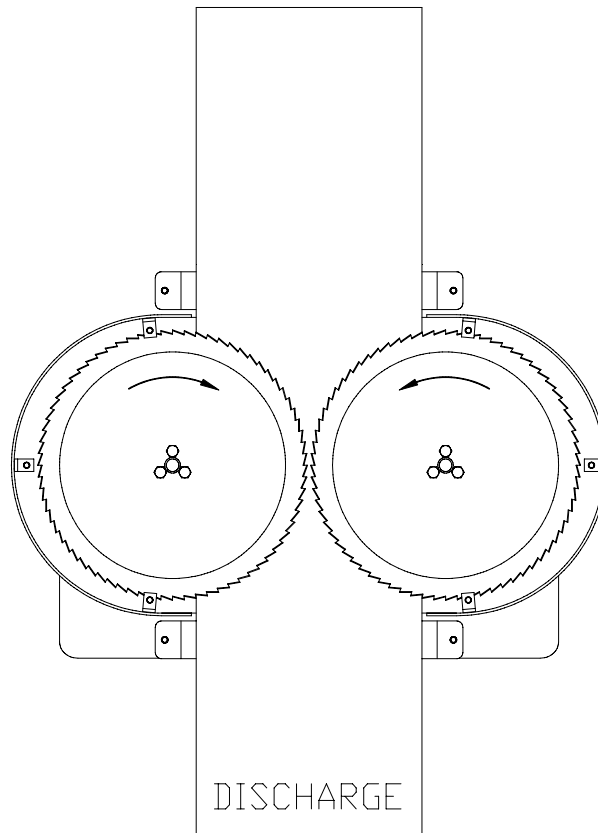

Continued on next page



---

## MODEL 705-N DUAL BLADE BUN SLICER

---

### CHANGING THE BLADES (Continued)

- Each BLADE can then be replaced by reversing the above procedure.
- When reinstalling the BLADES, make sure that the points on the teeth are pointed in opposite directions as shown on the previous page.

<b>NOTE</b>
-------------

STANDING ON THE DISCHARGE SIDE OF THE MACHINE LOOKING AT THE SHAFT END OF THE MOTORS THE LEFT HAND BLADE SHOULD ALWAYS ROTATE CLOCKWISE WHILE THE RIGHT HAND BLADE SHOULD ALWAYS ROTATE COUNTER CLOCKWISE.

<b>WARNING</b>
----------------

DO NOT START THE SLICER UNTIL ALL GUARDS ARE IN PLACE AND SECURELY FASTENED AND YOU HAVE MADE SURE THAT THE BLADES ARE NOT HITTING ANY OF THE METAL PARTS.



---

MODEL 705-N DUAL BLADE BUN SLICER

---

**TROUBLE SHOOTING**

**WARNING**

NEVER ATTEMPT TO CLEAN OR SERVICE THIS MACHINE UNTIL IT HAS BEEN DISCONNECTED FROM THE POWER SUPPLY AND YOU ARE SURE THE BLADES HAVE STOPPED.

THE SLICER MOTOR OR MOTORS WILL NOT START OR WERE RUNNING BUT SUDDENLY STOPPED.

- If both motors have stopped check to see if the machine's plug was accidentally removed.
- If plugged in, is the outlet working? Test it with another, working, small appliance.
- Your slicer's motors are equipped with thermal overloads. Should a motor become overheated it will stop. (See "Resetting the Thermal Overload" below)
- If you still can not find the problem have a qualified electrician check the unit's motors and switch.

**RESETTING THE MOTOR'S THERMAL OVERLOAD**

- To restart the machine allow the motor or motors to cool for approximately one and one half to two hours. Then carefully tip the machine back so that you can press the reset button. This button could be located on the end of the motor or on the end of its conduit box. Press the buttons FIRMLY. Return the machine to its proper position, connect it to the power supply and attempt to restart the machine.

**NOTE**

ATTEMPTING TO START THE MACHINE AFTER PRODUCT HAS BEEN INSERTED IN THE MACHINE OR ATTEMPTING TO CUT PRODUCT WITH A DIRTY BLADES MAY CAUSE OVERLOADS.



---

MODEL 705-N DUAL BLADE BUN SLICER

---

**REPLACEMENT PARTS LIST**

<b><u>ITEM NO.</u></b>	<b><u>PART DESCRIPTION</u></b>	<b><u>PART NUMBER</u></b>
001	Adapter-Blade STST	0702-0025
002	Rod -Threaded 5/16-18UNC Nylon	5840-8075
003	Screw-Soc. set 5/16-18 x 1/4	5842-6143
004	Frame-Dual Blade Bun Slicer	0705-0001-1
005	Bumper-Rubber	5918-6633
006	Knife-STST Scalloped	7107-7053
007	Screw-Hex HD 1/4-20x1/2 STST	5843-1001
008	Washer-1/4 STST Lock	5851-9395
009	Leg Assembly	0705-0011
010	Nut-Acorn STST 5/16-18	5832-0584
101	Table-Standard	0705-0002
102	Wheel-Thumb	0703-0003
103	Screw-Clamp	4560-2508-1108
104	Bearing-Bronze Thrust	5254-3507
105	Nut-Elastic Lock 1/2-13 STST	5831-9091
106	Plate-Adjusting	0703-0004
107	Screw-Hex Head 1/4-20 x 1/2	5842-1501
108	Washer-1/4" Flat STST	5851-9304
109	Washer-Lock 1/4" STST	5851-9357
110	Guide-RH (adjustable)	0705-0006-0001
110	Guide-RH (fixed)	0705-0006-0011
111	Guide-LH (adjustable)	0705-0006-0002
111	Guide-LH (fixed)	0705-0006-0012
112	Knob-4 Prong 1/4-20	5911-7034
201	Guard-Overhead	0705-0003
202	Knob-4 Prong 1/4-20	5911-7034
203	Guard-Chute	0705-0004
204	Cap-Neoprene	5106-8920
205	Screw-Thumb 1/4-20x 1" STST	5843-0538
206	Screw-Hex HD 1/4-20 x 1/2 STST	5843-1001
207	Washer-Lock 1/4" STST	5851-9357
208	Holddown-Overhead	0705-0005
209	Bearing-Bronze Flange	5254-3110
211	Washer-1/2" Flat 18-8 STST	5851-9308
212	Knob-4 Prong 1/2-13	5911-7103
213	Spring-Comp	7015-4104
214	Door-Slow Down	0705-0007

To obtain Replacement Parts call Oliver Products Company at 1-800-253-3893  
Rev. 12/02/02



---

---

MODEL 705-N DUAL BLADE BUN SLICER

---

---

**REPLACEMENT PARTS LIST (Continued)**

<u>ITEM NO.</u>	<u>PART DESCRIPTION</u>	<u>PART NUMBER</u>
301	Scale-1 Thru 8	6402-8003
302	Scale-8 Thru 1	6402-8004
401	Motor-1/3 HP 1-50/60-115/230	6301-1641
* 402	Cord-Motor	0705-0009-001
403	Bushing-Strain Relief	5765-1071
404	Bushing-Strain Relief (Motor)	5765-1082
404	Bushing-Strain Relief (Enclosure)	5765-1124
405	Screw-Hex HD 3/8-16x3/4 STST	5843-1052
406	Washer-3/8 STST Lock	5851-9359
407	Enclosure Switch	0705-0008-1
408	Screw-Mach 8-32 x 1/2 STST	5843-5225
409	Light-Pilot "RED" (115v)	5709-0190
409	Light-Pilot "RED" (220v)	5709-0191
410	Starter-Manual (1/60/115 VAC mach's.)	5709-3043
410	Starter-Manual (1/60/230 VAC mach's.)	5709-3042
411	Cord-Power (1/60/115 VAC mach's.)	5765-8302
411	Cord-Power (1/60/230 VAC mach's.)	5765-8325
412	Nut-Lock	5766-7750
413	Wire-Ground	0619-0020
414	Screw- Rd Hd #10-24 x 3/8 STST	5843-5237
415	Washer-#10 STST Lock	5851-9394
416	Jumper-7"	0705-0010
417	Joint-Wire	5768-1239
418	Cap-Plug (1/60/230 VAC mach's.)	5765-2030
* 419	Splice-Closed End	5768-1240

To obtain Replacement Parts call Oliver Products Company at 1-800-253-3893

\* Rev. 12/02/02





### MODEL 705-N DUAL BLADE BUN SLICER

#### ASSEMBLY DRAWING MODEL 705-N

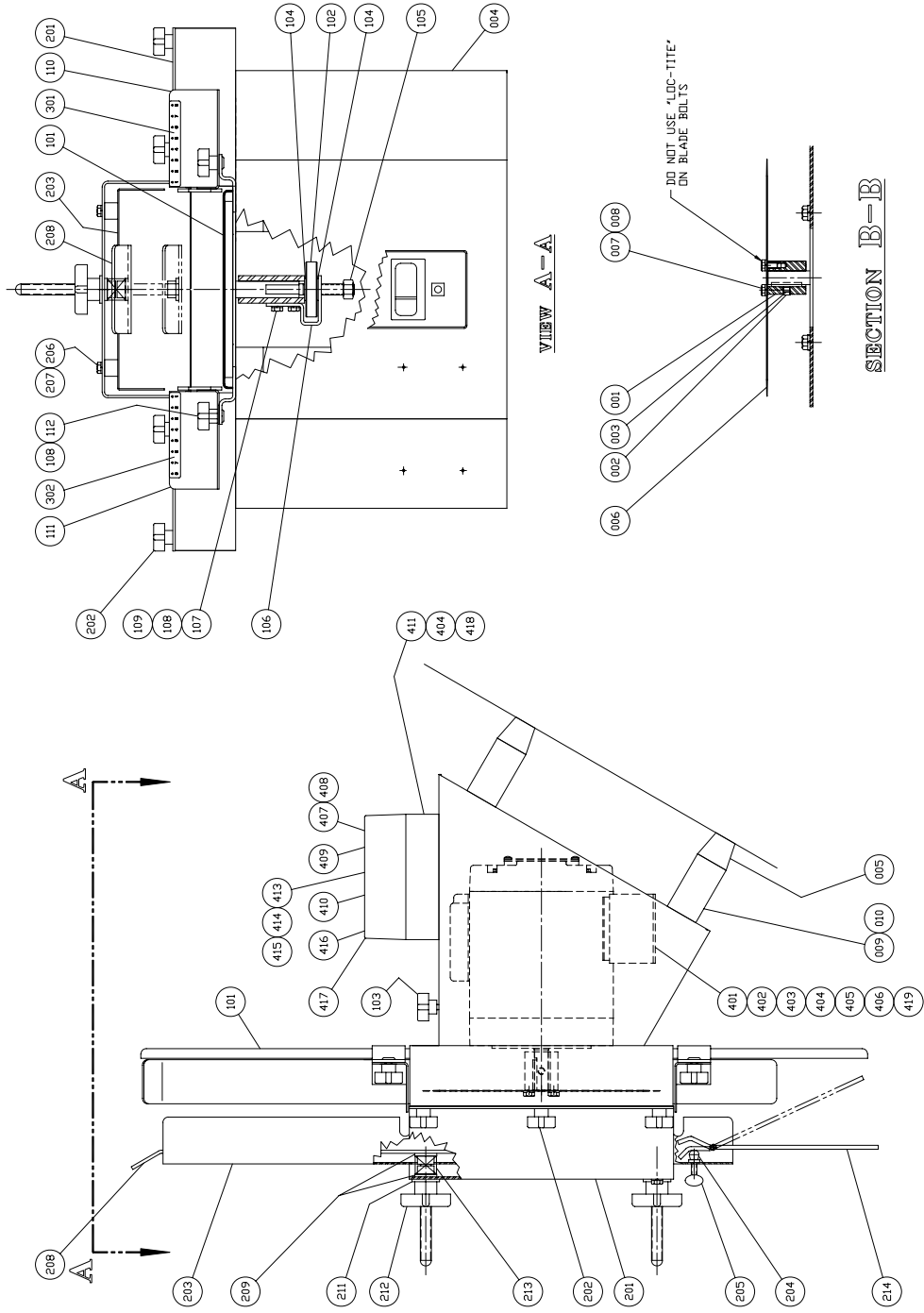

Rev. 12/4/02



MODEL 705-N DUAL BLADE BUN SLICER

WIRING DIAGRAMS

Wiring Diagram (2/3 HP, 1Ph, 50/60 Hz, 115/110 VAC)

Diagram No. 0705C12000

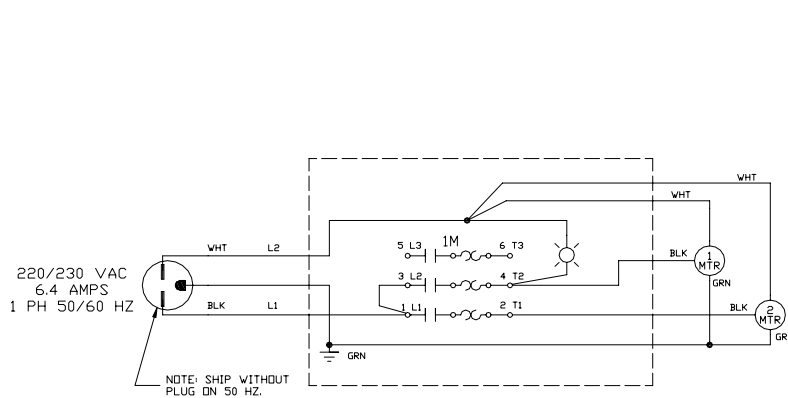

LEESON MOTOR  
CW ROTATION  
220/230 VAC  
MOTOR NO. 1

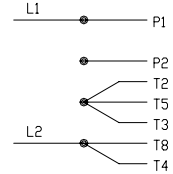

LEESON MOTOR  
CCW ROTATION  
220/230 VAC  
MOTOR NO. 2

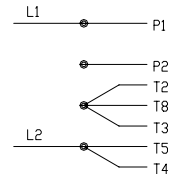

Wiring Diagram (2/3 HP, 1Ph, 50/60 Hz, 230/220 VAC)

Diagram No. 0705C12001

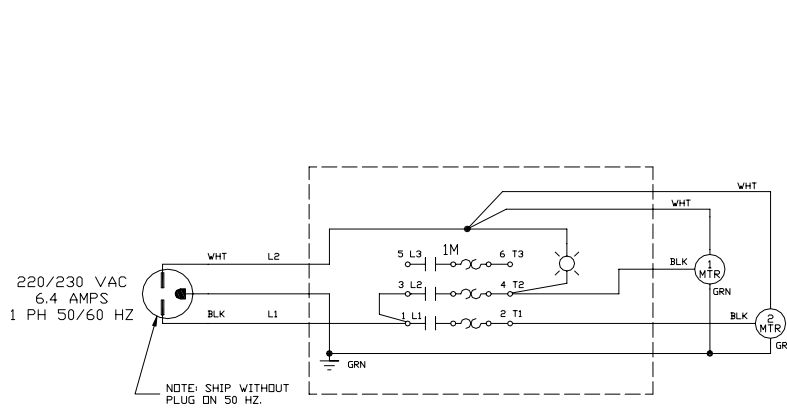

LEESON MOTOR  
CW ROTATION  
220/230 VAC  
MOTOR NO. 1

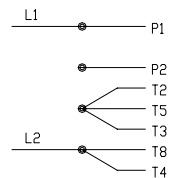

LEESON MOTOR  
CCW ROTATION  
220/230 VAC  
MOTOR NO. 2

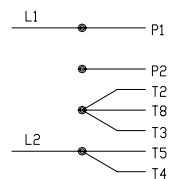

THIS PAGE WAS INTENTIONALLY  
LEFT BLANK.



Oliver Packaging & Equipment Company  
3236 WISON DR NW WALKER MI. 49534

(800) 253-3893  
www.oliverquality.com

## WARRANTY

### PARTS

Oliver Packaging & Equipment Company warrants that if any part of the equipment (other than a part not manufactured by Oliver Packaging & Equipment ) proves to be defective (as defined below) within one year after shipment, and if Buyer returns the defective part to Oliver Packaging & Equipment within one year, Freight Prepaid to Oliver Packaging & Equipment plant in Grand Rapids, MI, then Oliver Packaging & Equipment , shall, at Oliver Packaging & Equipment option, either repair or replace the defective part, at Oliver Packaging & Equipment expense.

### LABOR

Oliver further warrants that equipment properly installed in accordance with our special instructions, which proves to be defective in material or workmanship under normal use within one (1) year from installation or one (1) year and three (3) months from actual shipment date, whichever date comes first, will be repaired by Oliver Packaging & Equipment or an Oliver Packaging & Equipment Authorized Service Dealer, in accordance with Oliver Packaging & Equipment published Service Schedule.

For purposes of this warranty, a defective part or defective equipment is a part or equipment which is found by Oliver Packaging & Equipment to have been defective in materials workmanship, if the defect materially impairs the value of the equipment to Buyer. Oliver Packaging & Equipment has no obligation as to parts or components not manufactured by Oliver Packaging & Equipment, but Oliver Packaging & Equipment assigns to Buyer any warranties made to Oliver Packaging & Equipment by the manufacturer thereof.

This warranty **does not** apply to:

1. Damage caused by shipping or accident.
2. Damage resulting from improper installation or alteration.
3. Equipment misused, abused, altered, not maintained on a regular basis, operated carelessly, or used in abnormal conditions.
4. Equipment used in conjunction with products of other manufacturers unless such use is approved by Oliver Packaging & Equipment Company in writing.
5. Periodic maintenance of equipment, including but not limited to lubrication, replacement of wear items, and other adjustments required due to installation, set up, or normal wear.
6. Losses or damage resulting from malfunction.

The foregoing warranty is in lieu of all other warranties expressed or implied AND OLIVER PACKAGING & EQUIPMENT COMPANY MAKES NO WARRANTY OF MERCHANTABILITY OR FITNESS FOR PURPOSE REGARDING THE EQUIPMENT COVERED BY THIS WARRANTY. Oliver Packaging & Equipment Company neither assumes nor authorizes any person to assume for it any other obligations or liability in connection with said equipment. OLIVER PACKAGING & EQUIPMENT COMPANY SHALL NOT BE LIABLE FOR LOSS OF TIME, INCONVENIENCE, COMMERCIAL LOSS, INCIDENTAL OR CONSEQUENTIAL DAMAGES.

THIS PAGE WAS INTENTIONALLY  
LEFT BLANK.



Oliver Packaging & Equipment Company  
3236 WISON DR NW WALKER MI. 49534

(800) 253-3893  
[www.oliverquality.com](http://www.oliverquality.com)

## WARRANTY PROCEDURE

1. If a problem should occur, either the dealer or the end user must contact the Parts and Service Department and explain the problem.
2. The Parts and Service Manager will determine if the warranty will apply to this particular problem.
3. If the Parts and Service Manager approves, a Work Authorization Number will be generated, and the appropriate service agency will perform the service.
4. The service dealer will then complete an invoice and send it to the Parts and Service Department at Oliver Packaging & Equipment Company.
5. The Parts and Service Manager of Oliver Packaging and Equipment Company will review the invoice and returned parts, if applicable, and approve for payment.

THIS PAGE WAS INTENTIONALLY  
LEFT BLANK.



Oliver Packaging & Equipment Company  
3236 WISON DR NW WALKER MI. 49534

(800) 253-3893  
[www.oliverquality.com](http://www.oliverquality.com)

## RETURNED PARTS POLICY

This policy applies to all parts returned to the factory whether for warranted credit, replacement, repair or re-stocking.

Oliver Packaging and Equipment Company requires that the customer obtain a Return Material Authorization (RMA) number before returning any part. This number should appear on the shipping label and inside the shipping carton as well. All parts are to be returned prepaid. Following this procedure will insure prompt handling of all returned parts.

To obtain an RMA number contact the Repair Parts Department toll free at (800) 253-3893.

Parts returned for re-stocking are subject to a **RE-STOCKING CHARGE**.

Thank you for your cooperation,

Repair Parts Manager  
Oliver Packaging and Equipment Company