



Walker, Michigan, U.S.A. 49534-7564

USER'S OPERATING AND INSTRUCTION MANUAL

MODEL 702
MODEL 702-SE
MODEL 702-SS

BUN SLICERS



MODEL 702, 702SE and 702SS BUN SLICERS

INDEX

SLICER SPECIFICATIONS..... 0702S20019
 Description 0702S20019-1/2
 Specifications 0702S20019-1/2
 Product Capacities 0702S20019-2/2

SAFETY INSTRUCTIONS..... 0702S20020

DEFINITIONS GEN 931118

ADJUSTMENTS..... 0702S20022
 Outside Side Guide 0702S20022-1/2
 Table Height 0702S20022-1/2
 Inside Side Guide 0702S20022-1/2
 Slow-Down Door 0702S20022-2/2

OPERATING INSTRUCTIONS..... 0702S20023

MAINTENANCE/CLEANING/LUBRICATION..... 0702S20010

CHANGING THE BLADE..... 0702S20028

TROUBLE SHOOTING 0702S20024

PARTS LIST..... 0702S20026

ASSEMBLY DRAWING MODEL 702 SLICERS 0702S20021

ASSEMBLY DRAWING MODEL 702SE SLICERS 0702S20029

ASSEMBLY DRAWING MODEL 702SS SLICERS 0702S20030

WIRING DIAGRAMS 0702S20025

WARRANTY..... GEN 040225

WARRANTY PROCEDURE GEN 040226

RETURN PARTS POLICY GEN 040227



MODEL 702, 702SE and 702SS BUN SLICERS

SPECIFICATIONS

DESCRIPTION

These bun slicers have welded steel frames and stainless steel chutes. They are compact, durable slicers for counter top use in slicing a variety of buns with speed and economy.

SPECIFICATIONS

- Machine dimensions: Model 702

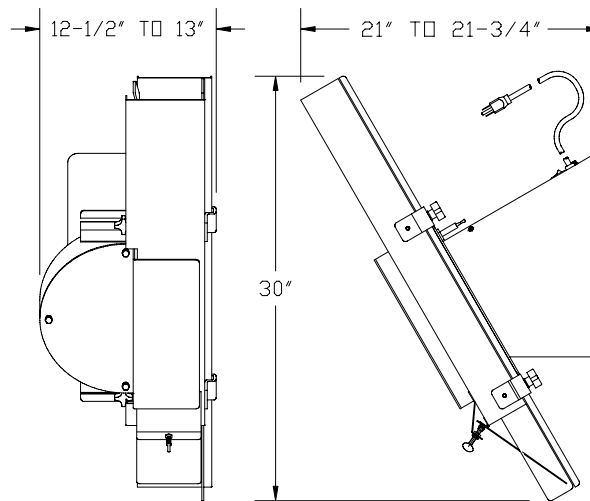

- Machine dimensions: Model 702SE

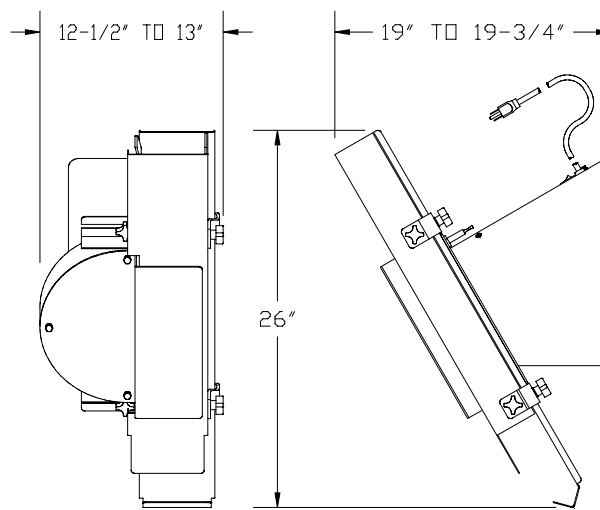



MODEL 702, 702SE and 702SS BUN SLICERS

- Machine dimensions: Model 702SS

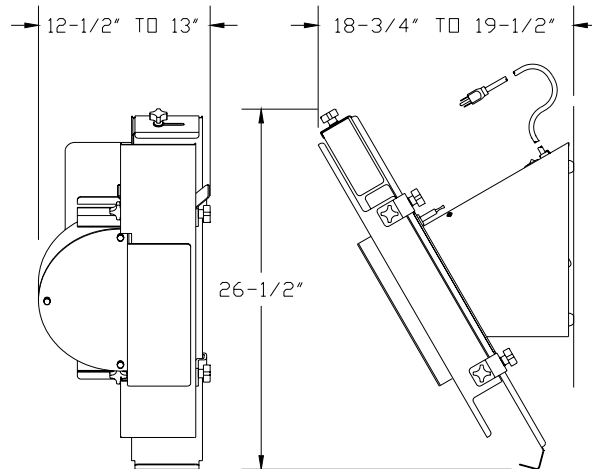

- Weight: Approximately (70) pounds.
- Standard Color: Gloss white enamel.
- Standard Electrical Service:
1/3 HP, 1725 RPM, 1-60-115 Volts AC, 6 Amps.
- Optional Electrical Services:
1/3 HP, 1725 RPM, 1-60-230 Volts AC, 3.5 Amps.
1/3 HP, 1425 RPM, 1-50-220 Volts AC, 3.5 Amps.

PRODUCT CAPACITIES

- Maximum Product Size:
4-7/8 inches Wide and 3 inches High
- Blade Height (adjustable):
5/8 inch to 1-1/2 inches
- Maximum Cutting Depth:
4-3/8 inches



MODEL 702, 702SE and 702SS BUN SLICERS

SAFETY INSTRUCTIONS

Every effort has been made by Oliver Products Company to provide you with a safe machine. It is essential, however, that machine operators and maintenance personnel observe the following safety precautions.

1. Before attempting to operate your slicer read this manual. Never allow an untrained person to operate this machine.
2. Make sure that the machine is only connected to a properly grounded electrical supply source of sufficient capacity for the load the slicer will put on it. Always unplug the machine when it is not in use.
3. Always make sure the machine has been disconnected from the power supply before cleaning or servicing.
4. Never stick your hand or any other objects into either end of the chute. Keep your hands away from the moving parts of the machine.
5. Never attempt to adjust or service this machine until your are **SURE** the blade has stopped.
6. Always make sure the knife is not rubbing or hitting any metal components before re-starting the machine.
7. All guards must be in place before starting the machine.
8. Handle knife blades with care. Do not touch the moving knife.
9. Use only proper replacement parts.
10. In addition to these general safety instructions, also follow the more specific safety instructions given for the different areas of the machine in the operating instructions.



GENERAL

DEFINITIONS

The use of the words WARNING, CAUTION, and NOTE in this manual should be guided by the following.

WARNING

AN OPERATING PROCEDURE, TECHNIQUE, ETC., WHICH MAY RESULT IN PERSONAL INJURY IF NOT CAREFULLY FOLLOWED.

CAUTION

AN OPERATING PROCEDURE, TECHNIQUE, ETC., WHICH MAY RESULT IN DAMAGE TO EQUIPMENT IF NOT CAREFULLY FOLLOWED.

NOTE

AN OPERATING PROCEDURE, TECHNIQUE, ETC., WHICH IS CONSIDERED ESSENTIAL TO EMPHASIZE.



MODEL 702, 702SE and 702SS BUN SLICERS

ADJUSTMENTS

WARNING

NEVER ATTEMPT TO ADJUST OR SERVICE THIS MACHINE UNTIL YOU ARE SURE THE BLADE HAS STOPPED.

OUTSIDE SIDE GUIDE

This guide is used to determine the amount of "Hinge" left on the product and can be adjusted from leaving approximately a 1/2" hinge to a complete sever.

The guide is adjusted by loosening the two knobs which are below and to the outside of the table and by sliding the guide in or out to generate the desired amount of hinge. Re-tighten the knobs when the guide is in the desired location.

CAUTION

MAKE SURE THAT THE BLADE IS NOT HITTING ANY OF THE OTHER COMPONENTS BEFORE RE-STARTING THE MACHINE.

TABLE HEIGHT ADJUSTMENT

The table can be adjusted so that the height of the blade above the table is between 5/8" and 1-1/2".

To change the height of the blade loosen the large knob on the front corner of the machine's base below the table. Once loosened the thumb screw below the table can be rotated clockwise to increase the table height (decrease bottom slice thickness), or rotated counter clockwise to decrease table height, (increase bottom slice thickness). Once the desired slice thickness is achieved re-tighten the large knob on the corner of the base to secure the table in the new position.

CAUTION

MAKE SURE THAT THE BLADE IS NOT HITTING ANY OF THE OTHER COMPONENTS BEFORE RE-STARTING THE MACHINE.

INSIDE SIDE GUIDE

Generally it is best to leave the inside guide adjusted to the maximum opening, this will allow the product to pass through uninhibited for maximum slicing speed. However, some products will require its use to reduce jamming.

(continued on next page)



Oliver Packaging & Equipment Company
3236 WISON DR NW WALKER MI. 49534

(800) 253-3893
www.oliverquality.com

MODEL 702, 702SE and 702SS BUN SLICERS

If it seems necessary to adjust this guide loosen the two knobs which are on the top and to the inside of the table, then slide the guide in or out to conform with product width. Make a liberal adjustment to allow for product variances. Re-tighten the knobs to secure it in the desired position.

SLOW-DOWN DOOR ADJUSTMENT (Model 702 only)

On the discharge end of the chute you will find a small adjustable door used to slow the product as it exits the blade. Generally heavier products require a lower door setting while lighter products require less restriction. The door is raised by turning the thumb screw in a clockwise direction. Turning the screw in the opposite direction will lower the door.

Normally if a bun should stop beneath the door the next bun should dislodge it, if it does not then the door should be adjusted to provide less restriction.

<u>WARNING</u>

NEVER STICK YOUR HAND OR ANY OTHER OBJECT INTO EITHER END OF THE CHUTE. ALWAYS KEEP YOUR HANDS AWAY FROM THE MOVING PARTS OF THE MACHINE.



Oliver Packaging & Equipment Company
3236 WISON DR NW WALKER MI. 49534

(800) 253-3893
www.oliverquality.com

MODEL 702, 702SE and 702SS BUN SLICERS

OPERATING INSTRUCTIONS

After adjustments for product width and bottom slice height have been made, (see adjustment section), you are ready to begin slicing your product.

Start the motor by turning the switch to the "ON" position, then place the product on the chute and allow it to slide into the blade, (do not throw the product into the machine). If the buns resist sliding freely into the blade simply use one or more additional buns to advance the first into slicing position.

WARNING

NEVER STICK YOUR HAND OR ANY OTHER OBJECT INTO EITHER END OF THE CHUTE. KEEP YOUR HANDS AWAY FROM THE MOVING PARTS OF THE MACHINE.

On Model 702 machines, should the sliced bun stop under the discharge door, the next bun through the blade will generally dislodge it. If this does not happen, re-adjust the slow down door or inside guide, see adjustment section of this manual.



MODEL 702, 702SE and 702SS BUN SLICERS

MAINTENANCE/CLEANING/LUBRICATION

WARNING

NEVER ATTEMPT TO CLEAN OR SERVICE THIS MACHINE UNTIL IT HAS BEEN DISCONNECTED FROM THE POWER SUPPLY AND YOU ARE SURE THE BLADE HAS STOPPED. ALSO REMEMBER TO USE CARE WHENEVER YOU ARE WORKING NEAR THE BLADE.

MAINTENANCE

Other than normal cleaning and occasional blade replacement little other regular maintenance is required.

CLEANING

Use a mild detergent solution or spray cleaner on all exterior and interior surfaces as necessary. Periodically remove the overhead guard assembly and blade guard, then brush, or vacuum, all foreign material from below the chute and from the blade compartment.

- Remove the blade guard by removing the three hex head screws which hold it in place. Lift it clear of the machine and set it one side.
- Remove the outside side guide and chute guard assembly by completely removing both knobs which secure it in place.

The blade will need to be removed and cleaned occasionally due to product build up, especially when cutting fruity or sticky breads. See "Changing the Blade" latter in this manual for instruction on how to remove the blade.

WARNING

ALWAYS USE CARE WHEN HANDLING AND CLEANING KNIVES.

LUBRICATION

No lubrication is required. The motor is equipped with pre-lubricated sealed bearings which require NO lubrication, **DO NOT** attempt to oil or grease the motor.



MODEL 702, 702SE and 702SS BUN SLICERS

CHANGING THE BLADE

WARNING

NEVER ATTEMPT TO CLEAN OR SERVICE THIS MACHINE UNTIL IT HAS BEEN DISCONNECTED FROM THE POWER SUPPLY AND YOU ARE SURE THE BLADE HAS STOPPED. ALSO REMEMBER TO USE CARE WHENEVER YOU ARE WORKING NEAR THE BLADE.

CHANGING THE BLADE

- Remove the overhead guard assembly by removing the three hex head screws which hold it in place. Lift the assembly clear of the machine and set it one side.
- Remove the outside side guide and chute guard assembly by completely removing both knobs which secure it in place.
- Using an "Allen" wrench remove the three screws securing the blade to the hub and lift the blade from the machine.
- The blade can then be replaced by reversing the above procedure.
- When reinstalling the blade, make sure that the points on the teeth are pointed in a counter clockwise direction.

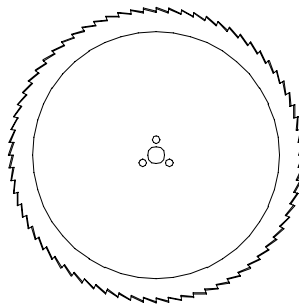

NOTE

LOOKING AT THE SHAFT END OF THE MOTOR THE BLADE SHOULD ALWAYS ROTATE CLOCKWISE.

WARNING

DO NOT START THE SLICER UNTIL ALL GUARDS ARE IN PLACE AND SECURELY FASTENED AND YOU HAVE MADE SURE THAT THE BLADE IS NOT HITTING ANY OF THE METAL PARTS.



MODEL 702, 702SE and 702SS BUN SLICERS

TROUBLE SHOOTING

WARNING

NEVER ATTEMPT TO CLEAN OR SERVICE THIS MACHINE UNTIL IT HAS BEEN DISCONNECTED FROM THE POWER SUPPLY AND YOU ARE SURE THE BLADE HAS STOPPED.

THE SLICER MOTOR WILL NOT START.

- Check to see if the machine is plugged in.
- If plugged in, is the outlet working? Test it with another, working, small appliance.
- Your slicer's motor is equipped with a thermal overload. Should the motor become overheated it will stop. To restart allow the motor to cool for approximately five minutes, then reset the overload by pressing the red button on the case of the motor.
- If you still can not find the problem have a qualified electrician check the unit's motor and switch.

THE SLICER'S MOTOR WAS RUNNING BUT SUDDENLY STOPPED.

- Check to see if the machine's plug was accidentally removed.
- Your slicer's motor is equipped with a thermal overload. Should the motor become overheated it will stop. To restart allow the motor to cool for approximately five minutes, then reset the overload by pressing the red button on the case of the motor.
- If you still can not find the problem have a qualified electrician check the unit's motor and switch.



MODEL 702, 702SE and 702SS BUN SLICERS

REPLACEMENT PARTS LIST

<u>ITEM NO.</u>	<u>PART DESCRIPTION</u>	<u>PART NUMBER</u>
001	Frame	0702-0010-003
002	Adapter-Blade	0702-0025
003	Guard-Blade	0700-0003
005	Screw-Clamp	4560-2510-1104
006	Bushing-Strain Relief	5765-1071
007	Screw-Thumb 3/6-16 x 1-1/2	5843-0545
008	Foot-Rubber	5902-0011
009	Knife-Scalloped StSt	7107-7053
021	Guide-Outside (Model 702)	0700-0004
021	Guide-Outside (Model 702SE)	0702-0017
021	Guide-Outside (Model 702SS)	0702-0017-001
022	Bracket-Outside Guide (Model 702)	0702-0009
022	Bracket-Outside Guide (OTHERS)	0702-0018
024	Table (Model 702)	0700-0011
024	Table (Model 702SE)	0702-0016
024	Table (Model 702SS)	0702-0016-001
025	Guard-Overhead (Model 702)	0702-0001
025	Guard-Overhead (Model 702SE)	0702-0020
025	Guard-Overhead (Model 702SS)	0702-0020-001
026	Guide-Inside (Model 702)	0702-0002
026	Guide-Inside (Model 702SE)	0702-0019
026	Guide-Inside (Model 702SS)	0702-0019-001
027	Screw-Clamp	4560-2508-1106
028	Cap-Neoprene	5106-8920
029	Screw-Thumb 1/4-20 x 1-1/2	5843-0540
030	Knob-4 Prong	5911-7034
031	Stop-Bread	0702-0021
040	Cover-Switch & Light	0702-0008-002
041	Cord-Power 1-60-115 VAC	0709-0056-003
042	Motor 1/3 HP 1-50/60-115/230	6301-1641
043	Light-Pilot 115 VAC	5709-0021
043	Light-Pilot 230 VAC	5709-0012
044	Switch-Rocker	5757-3307
045	PUSHER – BAGEL	0702-0044
046	BRACKET – PUSHER	0702-0045



MODEL 702, 702SE and 702SS BUN SLICERS

ASSEMBLY DRAWING MODEL 702SE

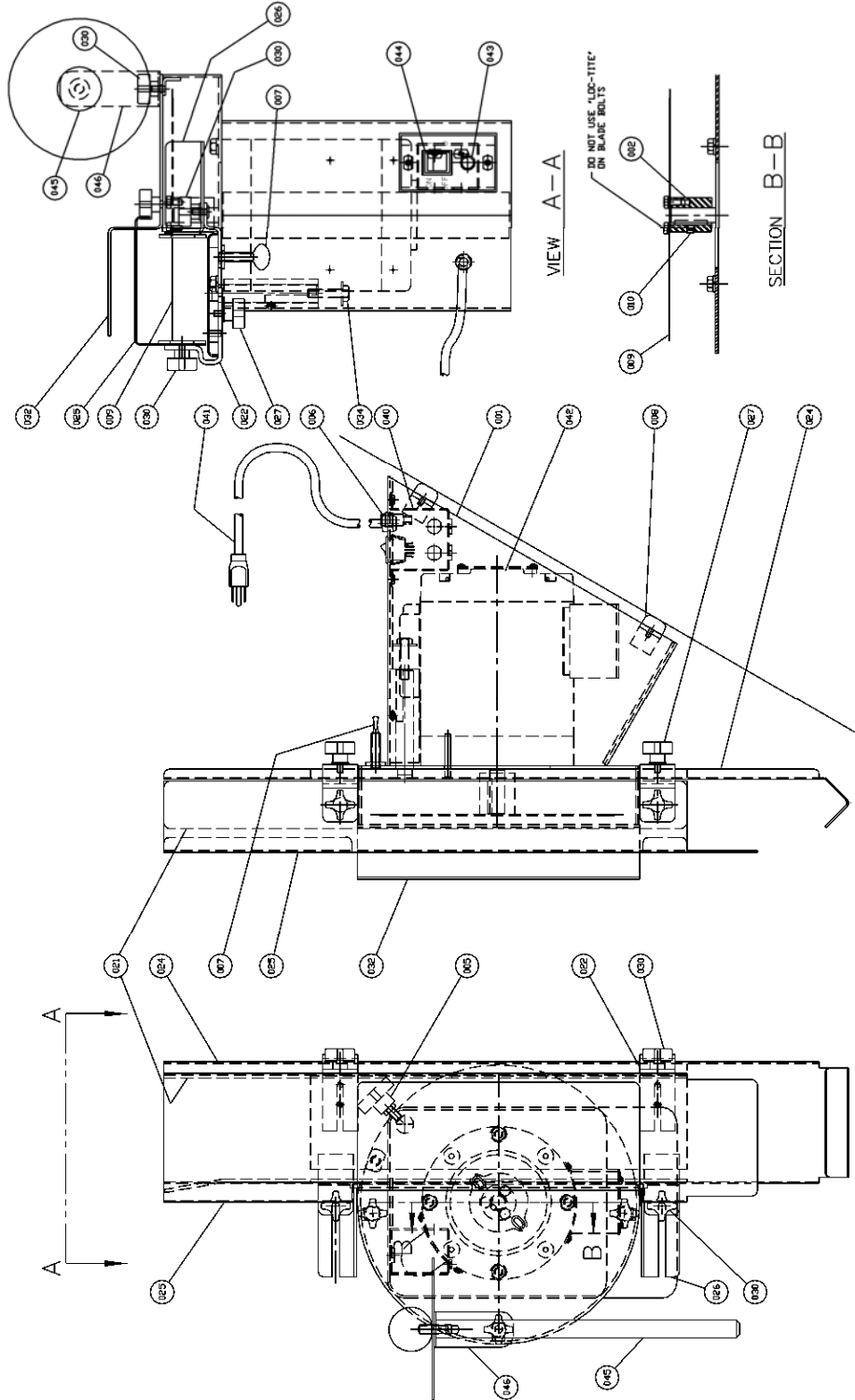



MODEL 702, 702SE and 702SS BUN SLICERS

ASSEMBLY DRAWING MODEL 702SS

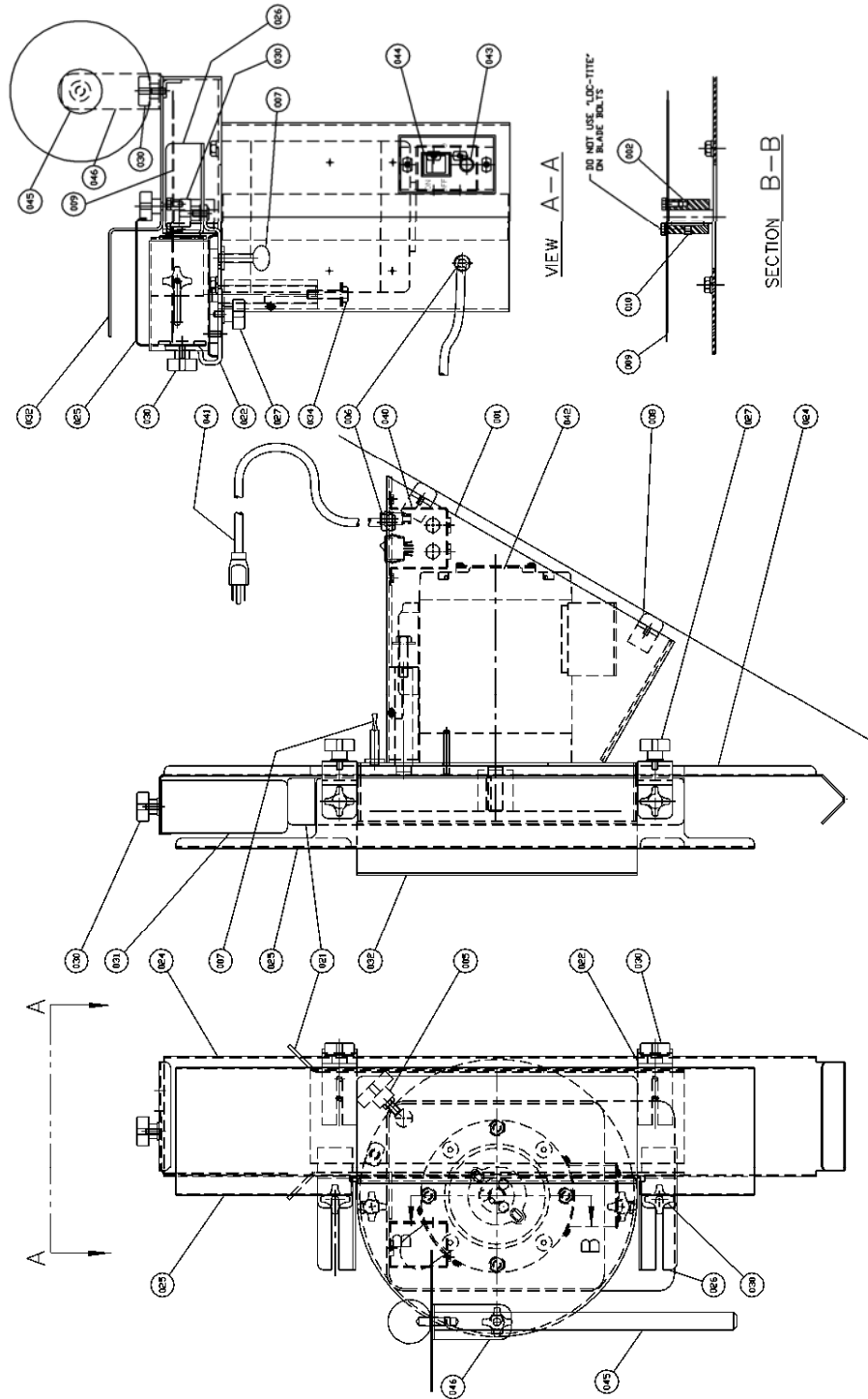



MODEL 702, 702SE and 702SS BUN SLICERS

WIRING DIAGRAMS

Wiring Diagram (1/3 HP, 1Ph, 50/60 Hz, 115 VAC)

Diagram No. 0702C12007

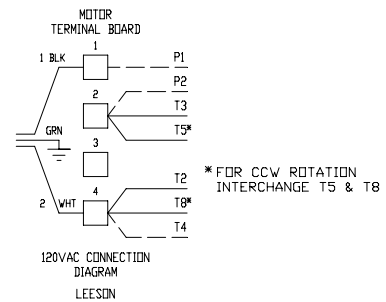
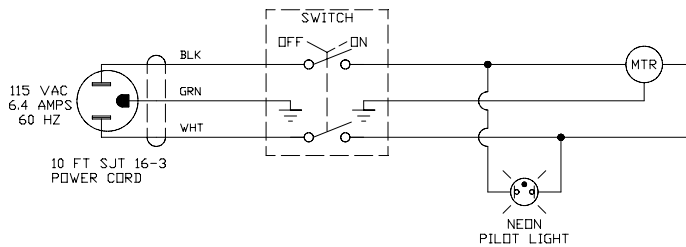

Wiring Diagram (1/3 HP, 1Ph, 50/60 Hz, 230 VAC)

Diagram No. 0702C12008

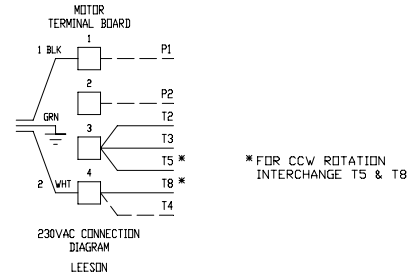
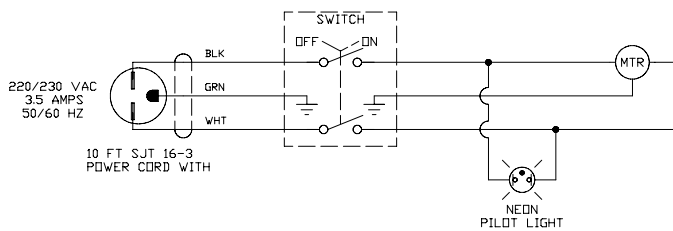



Oliver Packaging & Equipment Company
3236 WISON DR NW WALKER MI. 49534

(800) 253-3893
www.oliverquality.com

WARRANTY

PARTS

Oliver Packaging & Equipment Company warrants that if any part of the equipment (other than a part not manufactured by Oliver Packaging & Equipment) proves to be defective (as defined below) within one year after shipment, and if Buyer returns the defective part to Oliver Packaging & Equipment within one year, Freight Prepaid to Oliver Packaging & Equipment plant in Grand Rapids, MI, then Oliver Packaging & Equipment , shall, at Oliver Packaging & Equipment option, either repair or replace the defective part, at Oliver Packaging & Equipment expense.

LABOR

Oliver further warrants that equipment properly installed in accordance with our special instructions, which proves to be defective in material or workmanship under normal use within one (1) year from installation or one (1) year and three (3) months from actual shipment date, whichever date comes first, will be repaired by Oliver Packaging & Equipment or an Oliver Packaging & Equipment Authorized Service Dealer, in accordance with Oliver Packaging & Equipment published Service Schedule.

For purposes of this warranty, a defective part or defective equipment is a part or equipment which is found by Oliver Packaging & Equipment to have been defective in materials workmanship, if the defect materially impairs the value of the equipment to Buyer. Oliver Packaging & Equipment has no obligation as to parts or components not manufactured by Oliver Packaging & Equipment, but Oliver Packaging & Equipment assigns to Buyer any warranties made to Oliver Packaging & Equipment by the manufacturer thereof.

This warranty **does not** apply to:

1. Damage caused by shipping or accident.
2. Damage resulting from improper installation or alteration.
3. Equipment misused, abused, altered, not maintained on a regular basis, operated carelessly, or used in abnormal conditions.
4. Equipment used in conjunction with products of other manufacturers unless such use is approved by Oliver Packaging & Equipment Company in writing.
5. Periodic maintenance of equipment, including but not limited to lubrication, replacement of wear items, and other adjustments required due to installation, set up, or normal wear.
6. Losses or damage resulting from malfunction.

The foregoing warranty is in lieu of all other warranties expressed or implied AND OLIVER PACKAGING & EQUIPMENT COMPANY MAKES NO WARRANTY OF MERCHANTABILITY OR FITNESS FOR PURPOSE REGARDING THE EQUIPMENT COVERED BY THIS WARRANTY. Oliver Packaging & Equipment Company neither assumes nor authorizes any person to assume for it any other obligations or liability in connection with said equipment. OLIVER PACKAGING & EQUIPMENT COMPANY SHALL NOT BE LIABLE FOR LOSS OF TIME, INCONVENIENCE, COMMERCIAL LOSS, INCIDENTAL OR CONSEQUENTIAL DAMAGES.



Oliver Packaging & Equipment Company
3236 WISON DR NW WALKER MI. 49534

(800) 253-3893
www.oliverquality.com

WARRANTY PROCEDURE

1. If a problem should occur, either the dealer or the end user must contact the Parts and Service Department and explain the problem.
2. The Parts and Service Manager will determine if the warranty will apply to this particular problem.
3. If the Parts and Service Manager approves, a Work Authorization Number will be generated, and the appropriate service agency will perform the service.
4. The service dealer will then complete an invoice and send it to the Parts and Service Department at Oliver Packaging & Equipment Company.
5. The Parts and Service Manager of Oliver Packaging and Equipment Company will review the invoice and returned parts, if applicable, and approve for payment.



Oliver Packaging & Equipment Company
3236 WISON DR NW WALKER MI. 49534

(800) 253-3893
www.oliverquality.com

RETURNED PARTS POLICY

This policy applies to all parts returned to the factory whether for warranted credit, replacement, repair or re-stocking.

Oliver Packaging and Equipment Company requires that the customer obtain a Return Material Authorization (RMA) number before returning any part. This number should appear on the shipping label and inside the shipping carton as well. All parts are to be returned prepaid. Following this procedure will insure prompt handling of all returned parts.

To obtain an RMA number contact the Repair Parts Department toll free at (800) 253-3893.

Parts returned for re-stocking are subject to a **RE-STOCKING CHARGE**.

Thank you for your cooperation,

Repair Parts Manager
Oliver Packaging and Equipment Company